

Safety Precautions

1. This design of this product contains special hardware and many circuits and components specially for safety purposes. For continued protection, no changes should be made to the original design unless authorized in writing by the manufacturer. Replacement parts must be identical to those used in the original circuits. Services should be performed by qualified personnel only.
2. Alterations of the design or circuitry of the product should not be made. Any design alterations of the product should not be made. Any design alterations or additions will void the manufacturer's warranty and will further relieve the manufacture of responsibility for personal injury or property damage resulting therefrom.
3. Many electrical and mechanical parts in the products have special safety-related characteristics. These characteristics are often not evident from visual inspection nor can the protection afforded by them necessarily be obtained by using replacement components rated for higher voltage, wattage, etc. Replacement parts which have these special safety characteristics are identified in the Parts List of Service Manual. Electrical components having such features are identified by shading on the schematics and by (\triangle) on the Parts List in the Service Manual. The use of a substitute replacement which does not have the same safety characteristics as the recommended replacement parts shown in the Parts List of Service Manual may create shock, fire, or other hazards.
4. The leads in the products are routed and dressed with ties, clamps, tubings, barriers and the like to be separated from live parts, high temperature parts, moving parts and/or sharp edges for the prevention of electric shock and fire hazard. When service is required, the original lead routing and dress should be observed, and it should be confirmed that they have been returned to normal, after re-assembling.

5. Leakage current check (Electrical shock hazard testing)

After re-assembling the product, always perform an isolation check on the exposed metal parts of the product (antenna terminals, knobs, metal cabinet, screw heads, headphone jack, control shafts, etc.) to be sure the product is safe to operate without danger of electrical shock.

Do not use a line isolation transformer during this check.

- Plug the AC line cord directly into the AC outlet. Using a "Leakage Current Tester", measure the leakage current from each exposed metal parts of the cabinet, particularly any exposed metal part having a return path to the chassis, to a known good earth ground. Any leakage current must not exceed 0.5mA AC (r.m.s.).

- Alternate check method

Plug the AC line cord directly into the AC outlet. Use an AC voltmeter having, 1,000 ohms per volt or more sensitivity in the following manner. Connect a 1,500 Ω 10W resistor paralleled by a 0.15 μ F AC-type capacitor between an exposed metal part and a known good earth ground. Measure the AC voltage across the resistor with the AC voltmeter.

Move the resistor connection to each exposed metal part, particularly any exposed metal part having a return path to the chassis, and measure the AC voltage across the resistor. Now, reverse the plug in the AC outlet and repeat each measurement. Voltage measured any must not exceed 0.75 V AC (r.m.s.). This corresponds to 0.5 mA AC (r.m.s.).

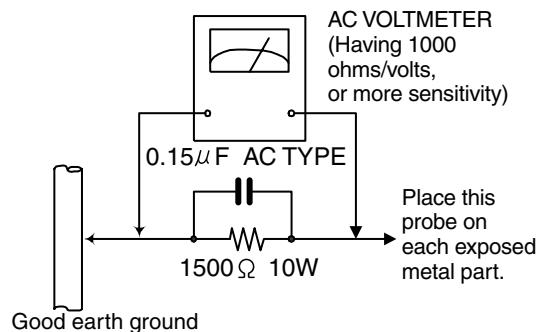

Warning

1. This equipment has been designed and manufactured to meet international safety standards.
2. It is the legal responsibility of the repairer to ensure that these safety standards are maintained.
3. Repairs must be made in accordance with the relevant safety standards.
4. It is essential that safety critical components are replaced by approved parts.
5. If mains voltage selector is provided, check setting for local voltage.

CAUTION

Burrs formed during molding may be left over on some parts of the chassis. Therefore, pay attention to such burrs in the case of performing repair of this system.

In regard with component parts appearing on the silk-screen printed side (parts side) of the PWB diagrams, the parts that are printed over with black such as the resistor (\blacksquare), diode (\blacksquare) and ICP (\bullet) or identified by the " \triangle " mark nearby are critical for safety.

When replacing them, be sure to use the parts of the same type and rating as specified by the manufacturer. (Excepted the J and C version)

Wiring connections

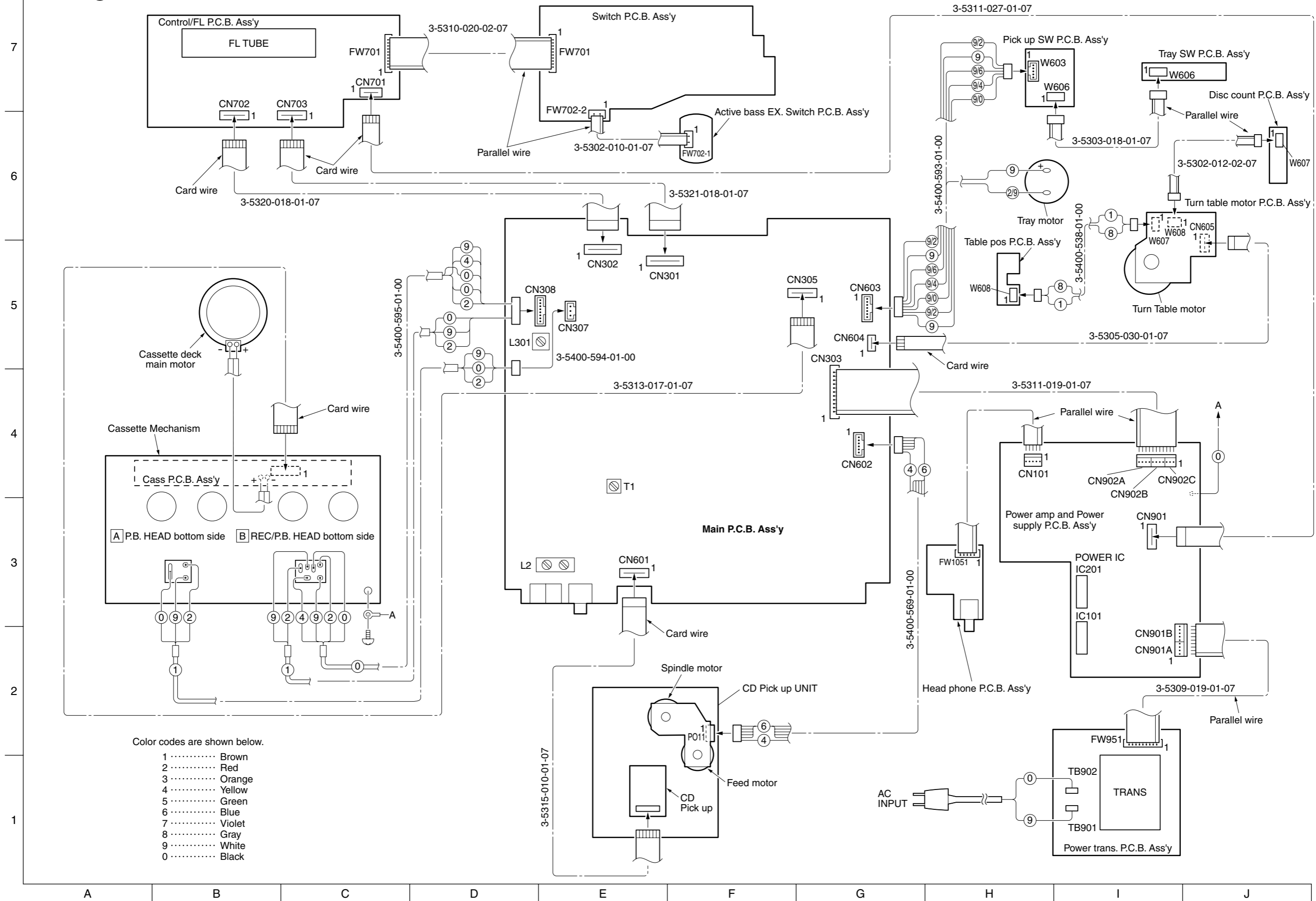

Block diagram

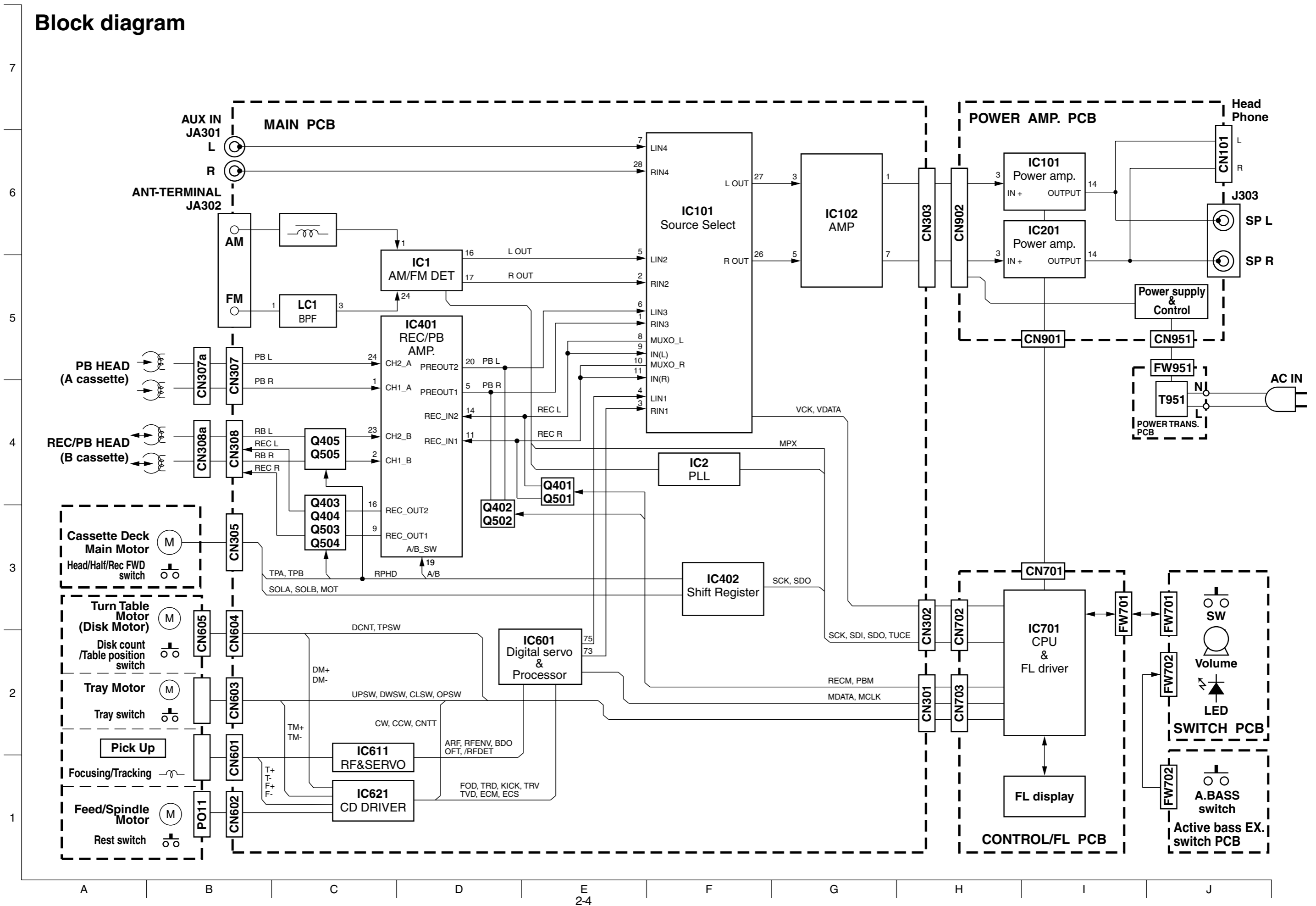

Standard schematic diagrams

■ Head AMP, tuner and audio section

7
6
5
4
3
2
1

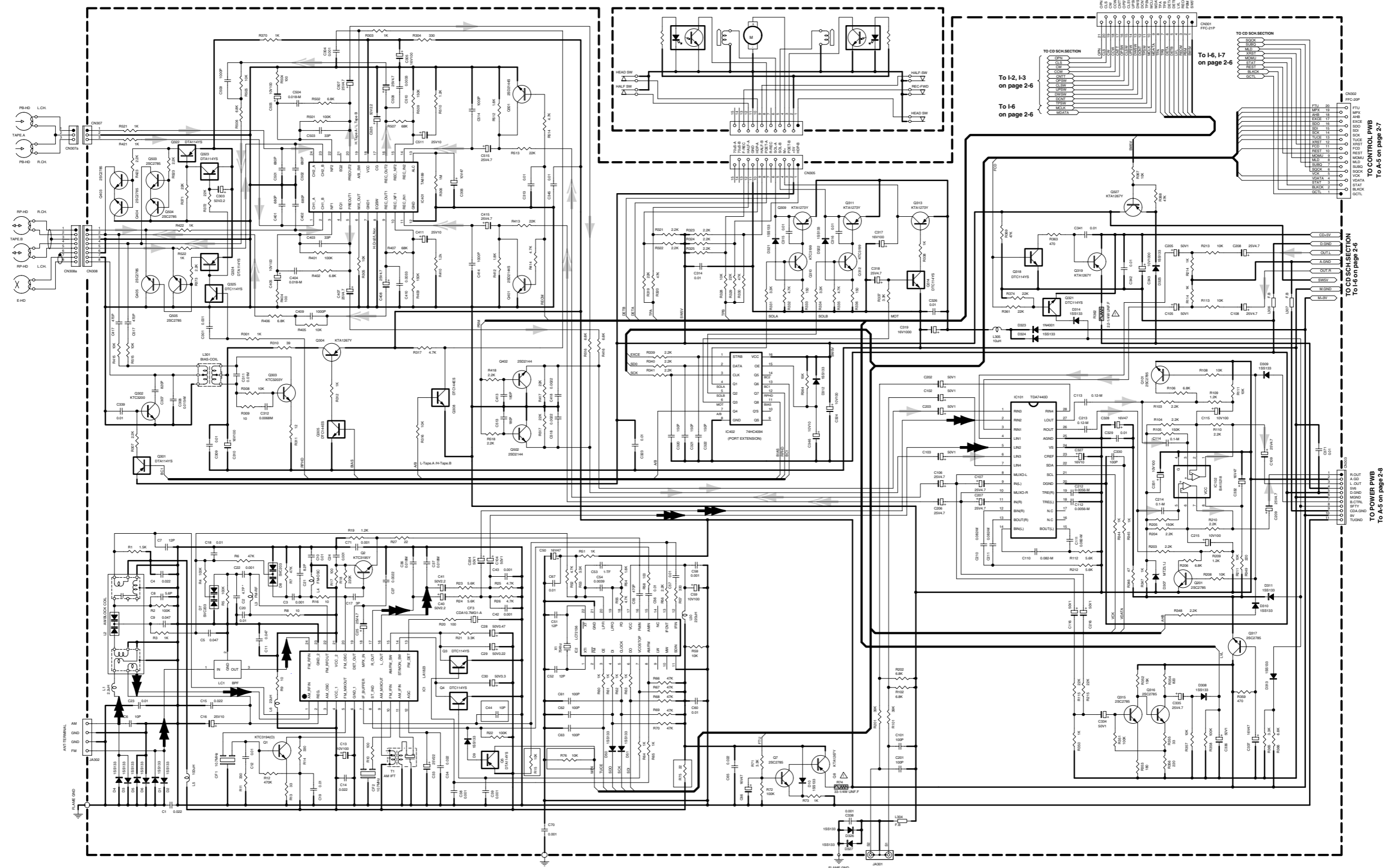

- CD/TAPE PLAY SIGNAL
- TAPE REC SIGNAL
- RADIO SIGNAL

Parts are safety assurance parts.
When replacing those parts make sure to use the specified one.

A B C D E F G H I J

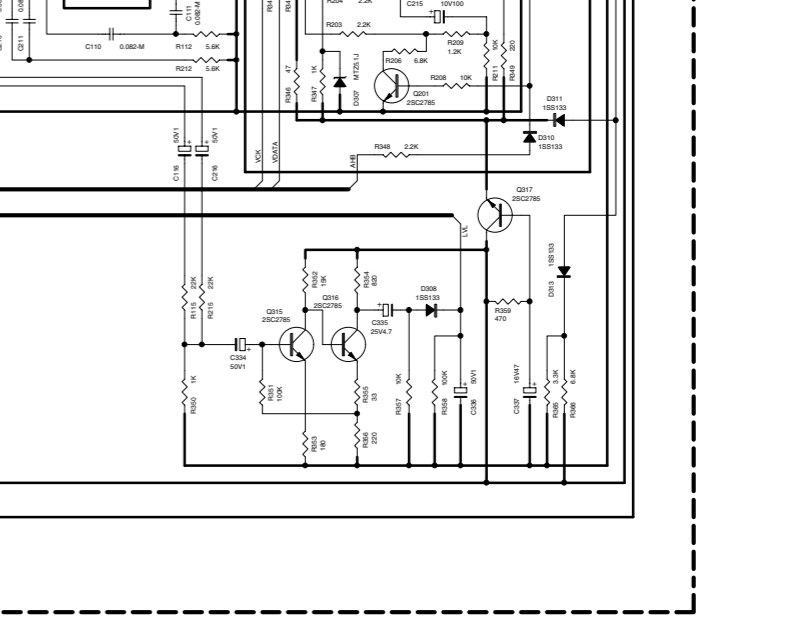
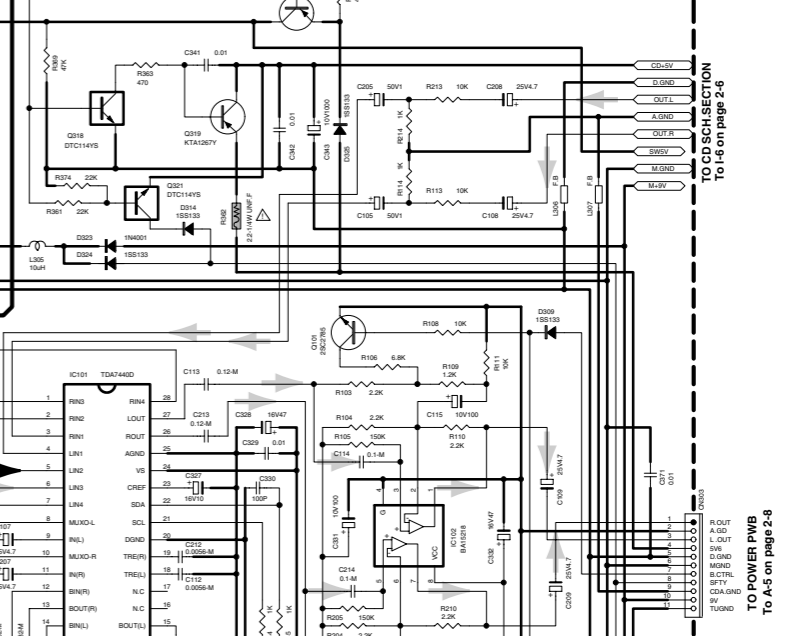
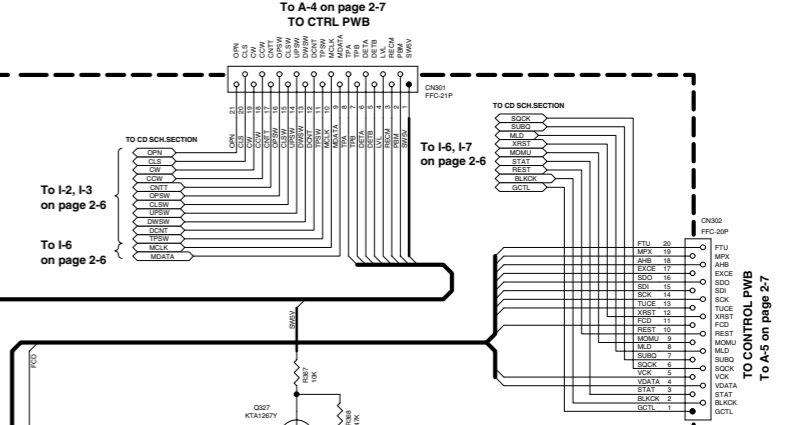

CD servo control section

7
6
5
4
3
2
1

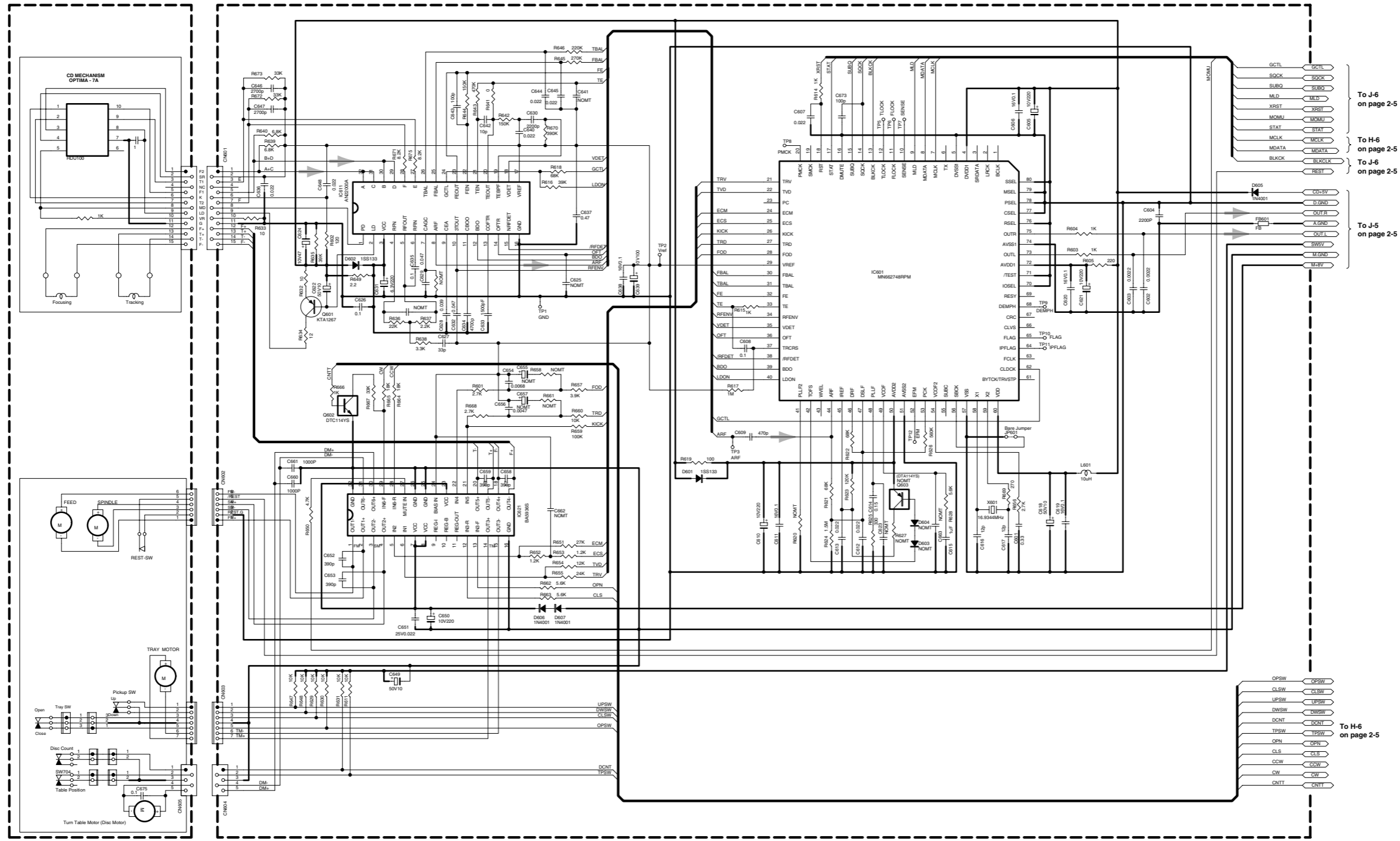

To J-6 on page 2-5

To H-6 on page 2-5
To J-6 on page 2-5

To J-5 on page 2-5

To H-6 on page 2-5

➔ CD SIGNAL

FL display and CPU section

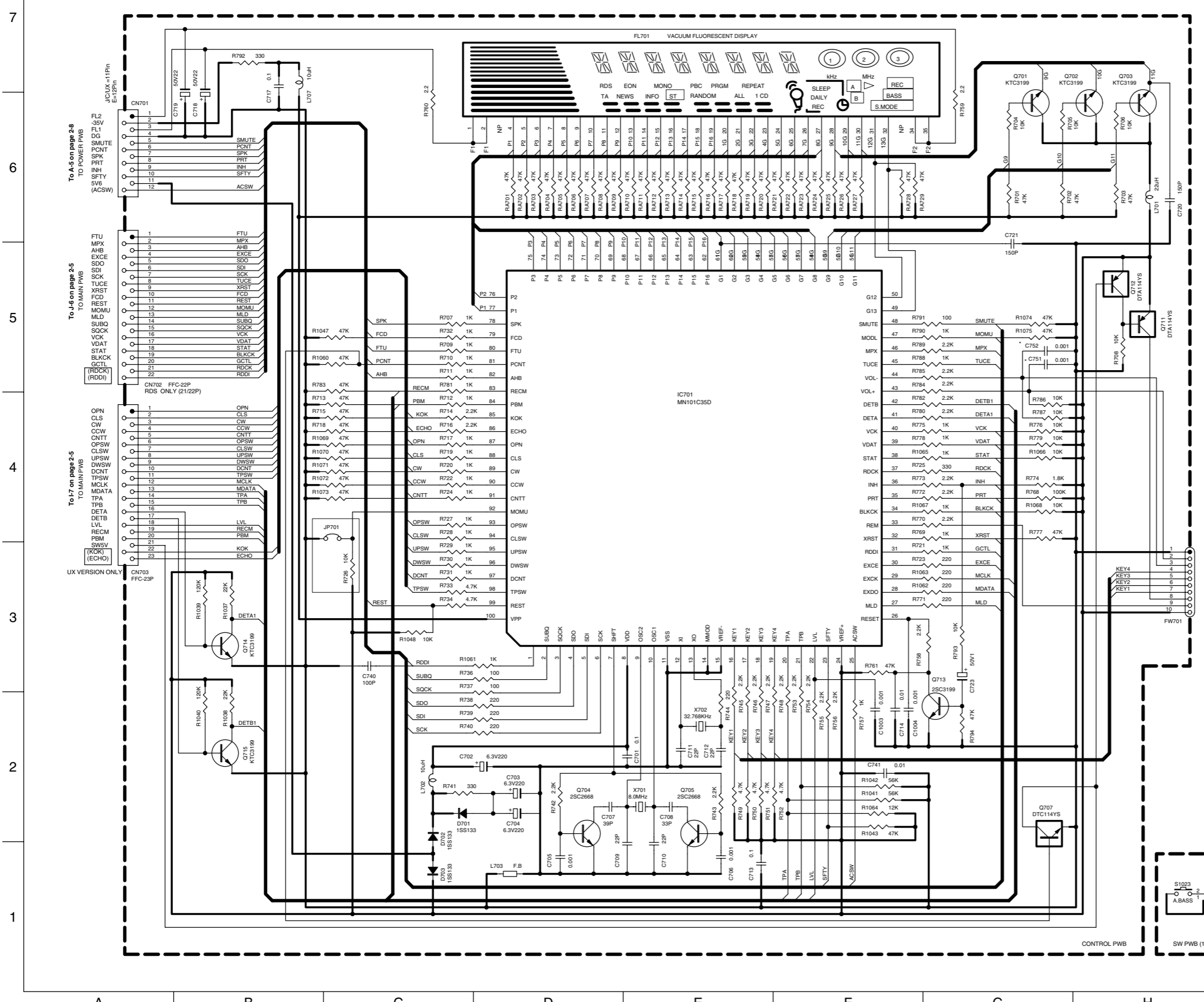

VERSION	Setting					ECO MODE
	R1006	R1007	R1016	JP701	R726	
J USA	Nil	Nil	Nil	YES (10K)	Nil	
C CANADA	Nil	Nil	Nil	YES (10K)	Nil	
E EUROPE	18K	8.2K	18K	Nil	10K	
B UK	18K	8.2K	18K	Nil	10K	
EN NORDIC	18K	8.2K	18K	Nil	10K	
EE RUSSIA	6.8K	820	18K	Nil	10K	
EV EAST EUROPE	18K	8.2K	18K	Nil	10K	
A Austria	12K	1.5K	Nil	Nil	(10K)	
US Singapore	4.7K	JW	Nil	YES (10K)	Nil	
UP Korea	12K	1.5K	18K	YES (10K)	Nil	
UX Saudi Arabia	Nil	Nil	18K	YES (10K)	Nil	
UY Argentina	Nil	Nil	18K	YES (10K)	Nil	
UW Latin America	4.7K	JW	Nil	YES (10K)	Nil	
UT Taiwan	4.7K	JW	Nil	YES (10K)	Nil	
UB Hong Kong	4.7K	JW	Nil	YES (10K)	Nil	
UJ US Mil	4.7K	JW	Nil	YES (10K)	Nil	

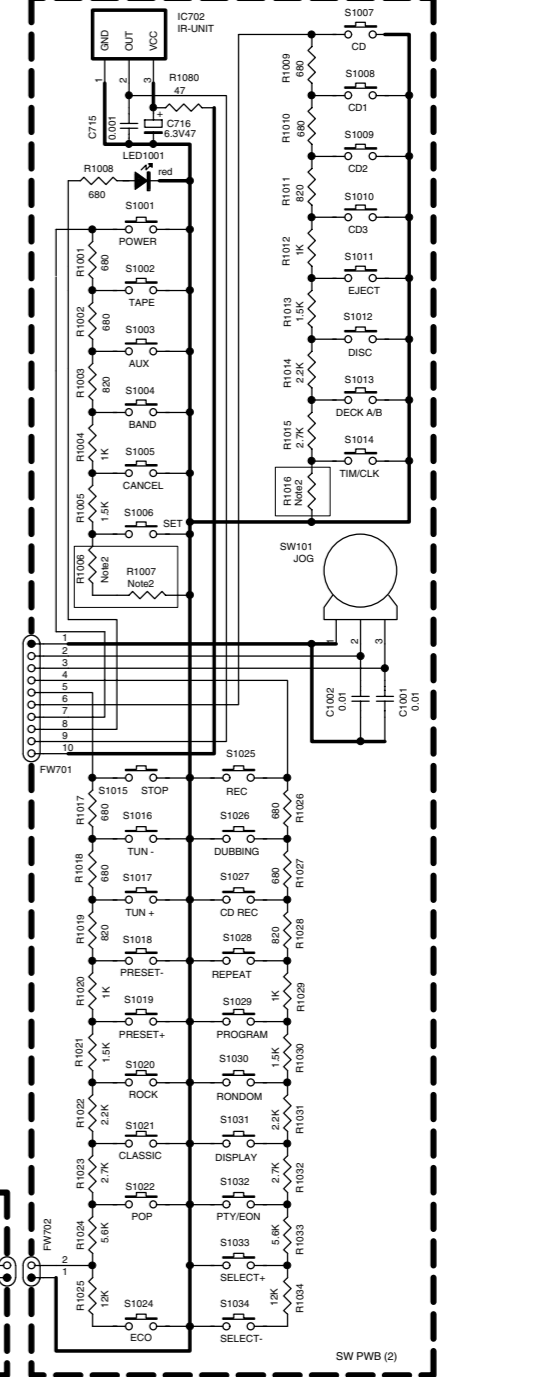

To A-5 on page 2-8 TO POWER PWB

To A-6 on page 2-5 TO MAIN PWB

To J-6 on page 2-5 TO MAIN PWB

To I-7 on page 2-5 TO MAIN PWB

UX VERSION ONLY

CONTROL PWB

SW PWB (1)

SW PWB (2)

Main amp. and power supply section

VERSION	SUB-POWER BOARD	INHIBIT CIRCUIT	CN981	JP901	C391 C392	C393 C394	C1053 C1054
J USA	NIL	YES	0	1	NIL	NIL	NIL
C CANADA	NIL	YES	0	1	NIL	NIL	NIL
E EUROPE	YES	NIL	1	0	3300P	0.001	0.001
B UK	YES	NIL	1	0	3300P	0.001	0.001
EN NORDIC	YES	NIL	1	0	3300P	0.001	0.001
EE RUSSIA	YES	NIL	1	0	3300P	0.001	0.001
EV EAST EUROP.	YES	NIL	1	0	3300P	0.001	0.001

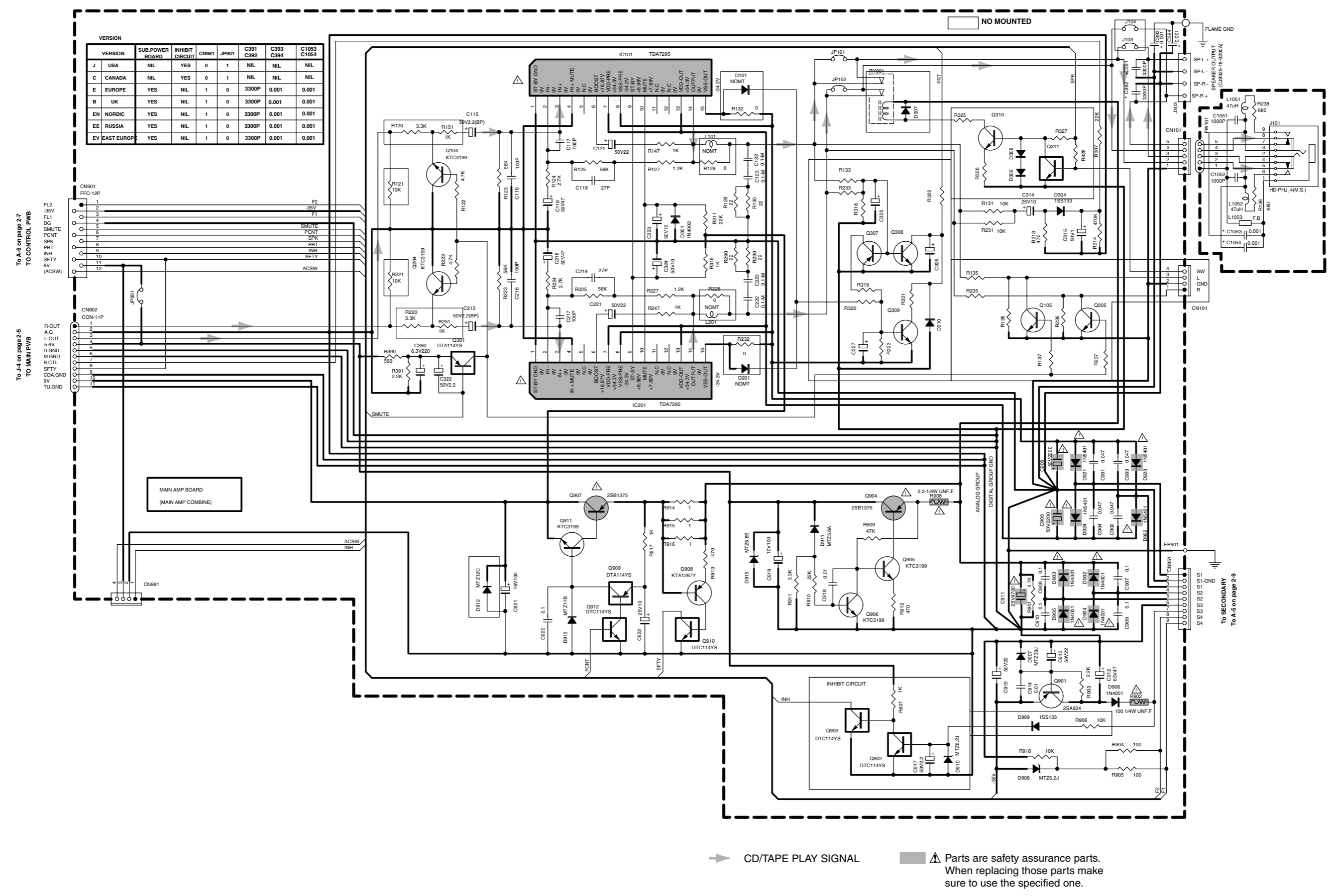

To A-6 on page 2-7
TO CONTROL PWB

To J-4 on page 2-5
TO MAIN PWB

MAIN AMP BOARD
(MAIN AMP COMBINE)

To A-5 on page 2-9
TO SECONDARY

➔ CD/TAPE PLAY SIGNAL

▲ Parts are safety assurance parts.
When replacing those parts make
sure to use the specified one.

■ Power transformer section

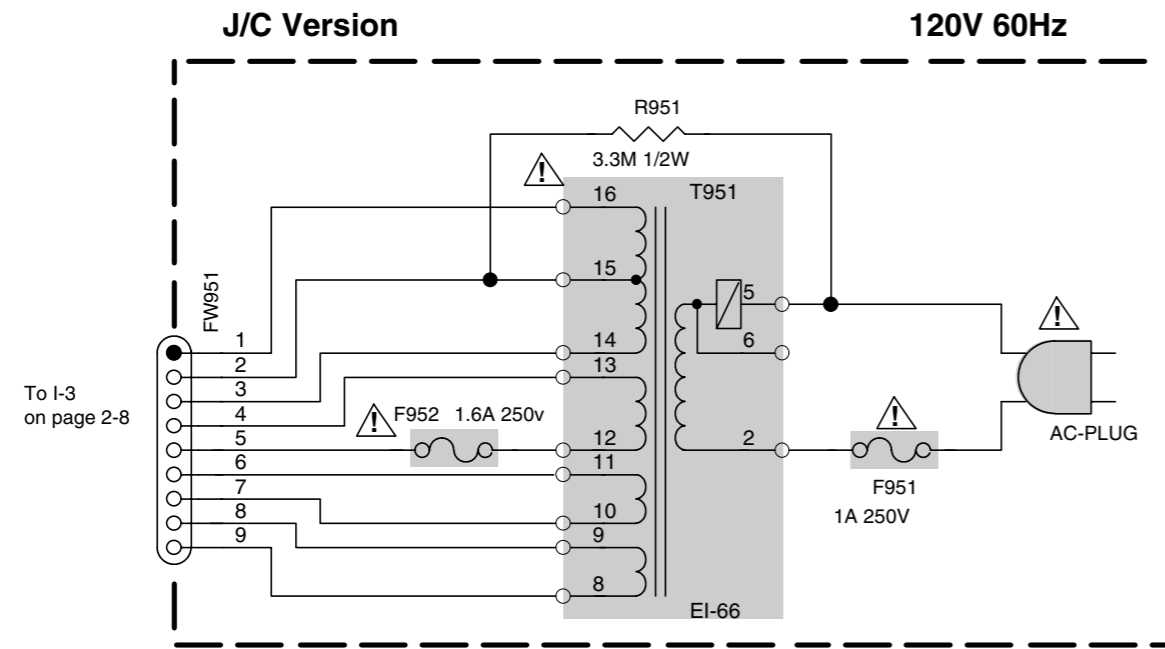

Parts are safety assurance parts. When replacing those parts make sure to use the specified one.

Printed circuit boards

■ Main circuit board

7
6
5
4
3
2
1

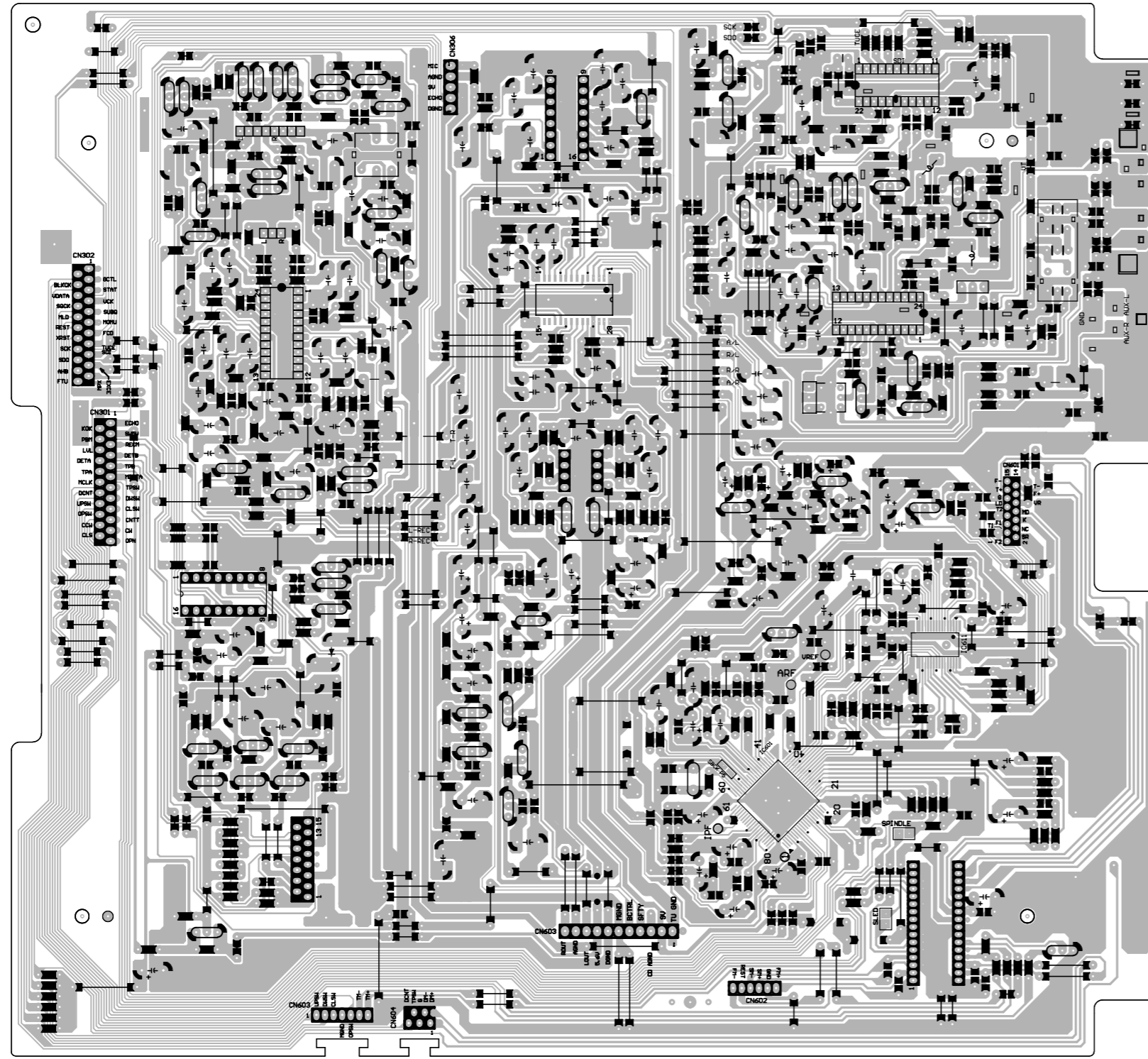

(MAIN PCB)

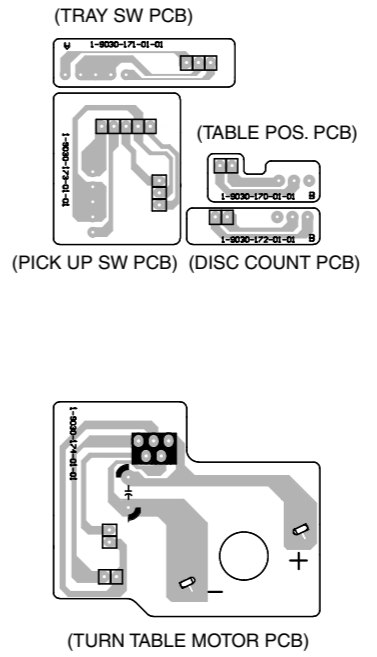

A B C D E F G H I J

Control/FL and Switch circuit board

(CONTROL/FL PCB)

(ACTIVE BASS EX. SWITCH PCB)

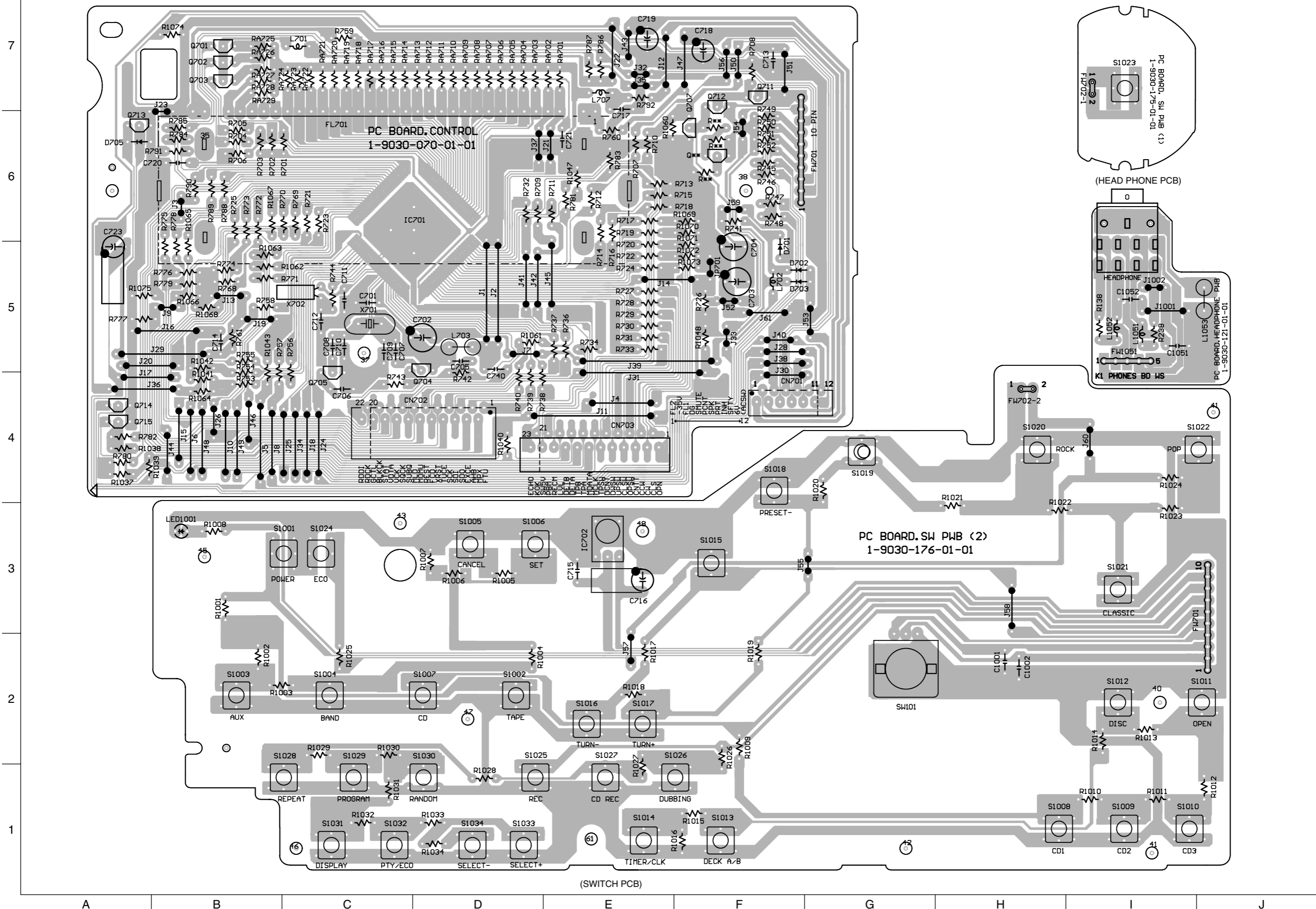

■ Power amp. and Power supply circuit board

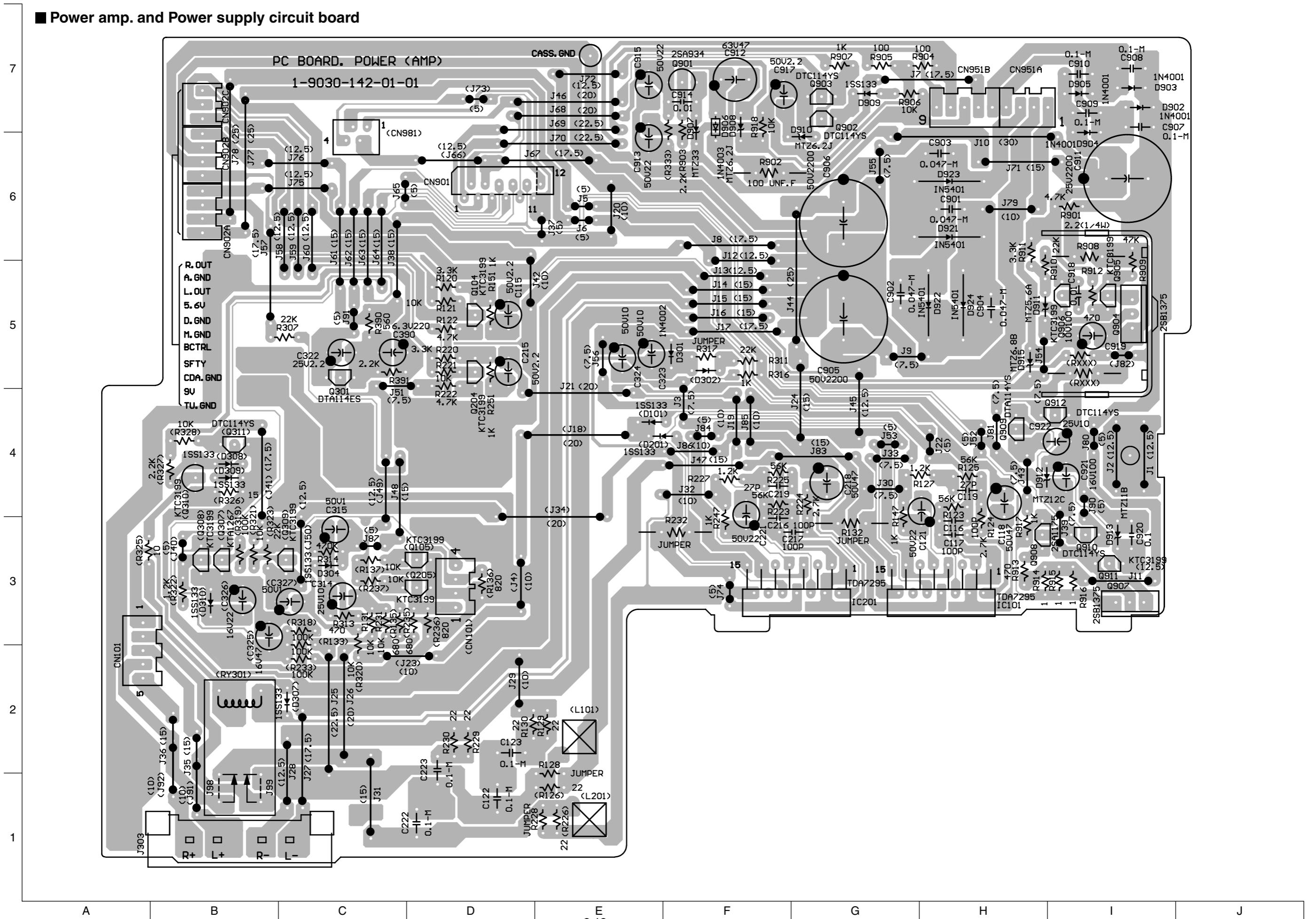

■ Power trans. circuit board

7

6

5

4

3

2

1

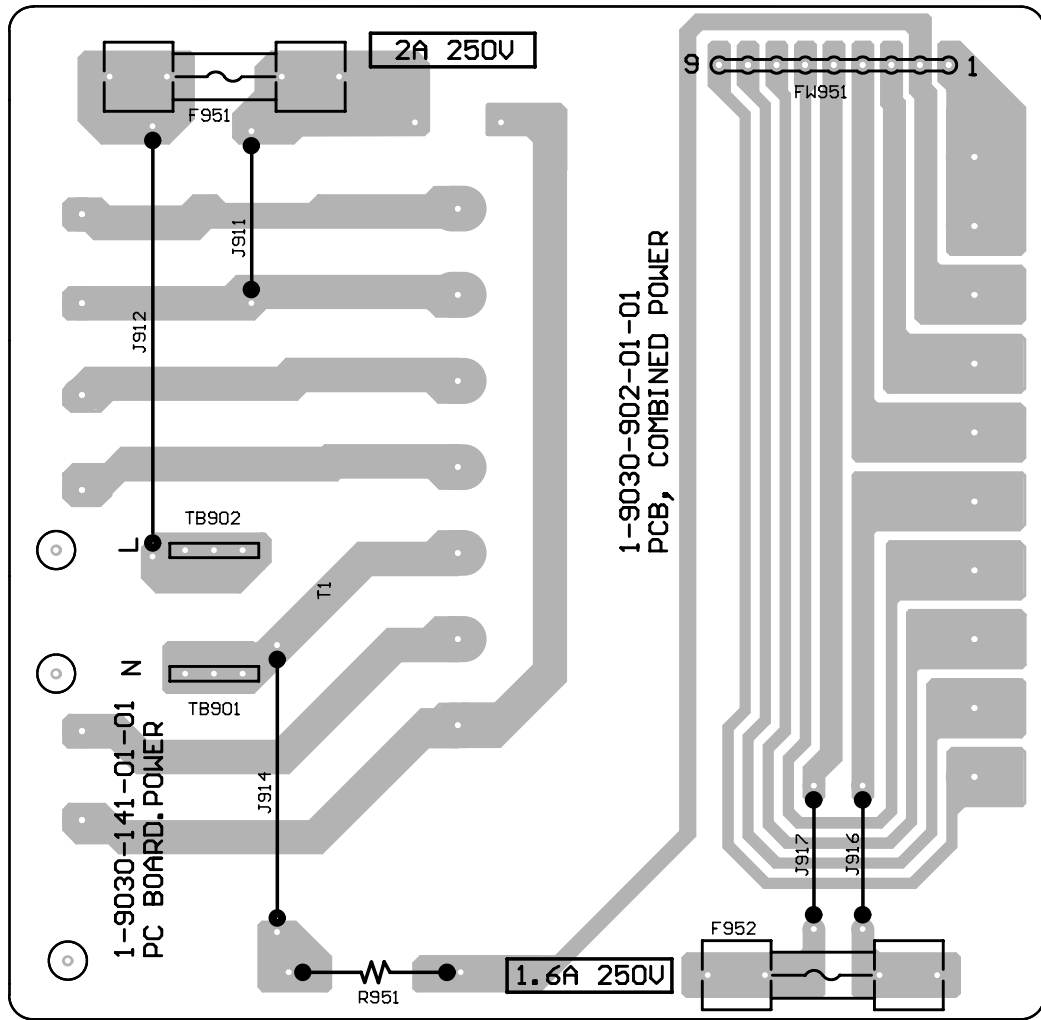

A

B

C

D

E

— MEMO —

— MEMO —